

CD-S1000

Super Audio CD Player

High sound quality Super Audio CD player

Differential D/A converters for high conversion precision with low noise

Exclusive Yamaha Loading Mechanism with Superior Quietness and High Precision CD Drive

Pure Direct



HiFi Began with Yamaha

Yamaha's involvement with and passion for music goes back more than a century, to when we built our first reed organ in 1887. Now we are the world's leading producer of pianos and other musical instruments, and are involved with music in many other ways as well. We manufacture professional recording equipment, we design concert halls and we assist artists at concerts with set up and sound tuning. This knowledge and experience benefits our production of audio components in many ways. We introduced our first HiFi (High Fidelity) turntable in 1954, becoming the first company to actually use the term "HiFi." Thereafter we were one of the first to offer mass-produced, high quality audio equipment, and introduced many legendary stereo components. We hope you enjoy the genuine HiFi experience of Yamaha Natural Sound.



Ultra high precision, Super Audio CD player that inherits the high sound quality design of the CD-S2000.

Designed, Built and Tuned for Truly Exceptional Music Reproduction Performance

The CD format has been with us for about 25 years, and even as new media emerge, it retains its popularity. Nowadays, multi-disc players are common and CDs can also be played on DVD players, but nevertheless, audiophiles still want dedicated single-disc players that offer the highest possible quality. Yamaha answers this desire with the CD-S1000 – capable of playing CDs and Super Audio CDs, it is designed and built with extreme attention to every detail, for exceptionally accurate music reproduction, with nothing added or lost.

The CD-S1000 inherits the high sound quality design of the CD-S2000, but without balanced output circuitry. The basic design features that earned the CD-S2000 its high reputation, such as the use of differential DACs for high conversion precision with low noise, as well as the Exclusive Yamaha Loading Mechanism with Superior Quietness and High Precision CD Drive, are the same in both models.

What really sets the CD-S1000 apart from its competitors, however, is that above and beyond the excellent electronic and mechanical performance, Yamaha designers have “tuned” the sound with a musician’s sensibility. Unlike, for example, new format DVD players that are as close to being computers as they are to audio components, the CD-S1000 was built by people

who thought of it as a musical instrument. The difference is apparent, especially when you pair it with the A-S1000 or other high-performance amplifier, which will give you the finest CD sound quality you’ve ever heard.

Differential D/A Converters

The CD-S1000 uses high-grade differential D/A converters for the left and right channels, with their output assigned separately for plus and minus. Developed by drawing on Yamaha’s long experience in digital technology, they ensure the highest conversion precision, as well as outstanding S/N ratio and dynamic range. All other components, including the analogue circuitry, were carefully selected based on extensive listening tests. Comprehensive sound tuning, encompassing even the mechanisms, means that you will enjoy incredibly dynamic and powerful CD reproduction.

D/A Converter Principle (L Channel)

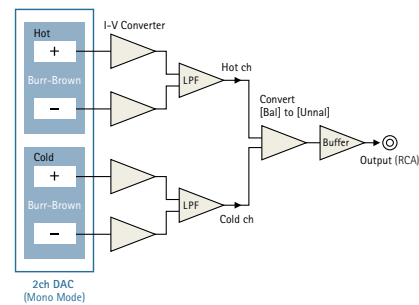

Exclusive Yamaha Loading Mechanism with Superior Quietness and High Precision CD Drive

The mechanism that picks up the signal is actually analogue, even during the digital reproduction of a CD. So its degree of precision has a surprisingly large effect on the reproduction of the digital signals and the final sound. The CD-S1000 features the Exclusive Yamaha Loading Mechanism with Superior Quietness, which uses Synchro Mesh rather than noise-producing gears, for totally silent tray movement as well as extremely high durability. The rest of the mechanism is also top quality, including a highly reliable brushless spindle motor and a diecast aluminium tray that is completely free of vibration. The thick steel and wood chassis is very heavy and stable, far superior to ordinary types made partly of plastic.



Four-Part Power Supply with Independent Structure

The power supply has four sections—for the audio circuitry, the digital circuitry, the drive mechanism, and the display—which are physically separated from each other and from the transformer, minimising both mutual interference that degrades sound quality and the effect on earth electric potential. The power supply for the audio circuitry is a constant current type with an independent left-right structure; it ensures a stable supply of clean power and contributes to superior channel separation.

Power Supply Configuration

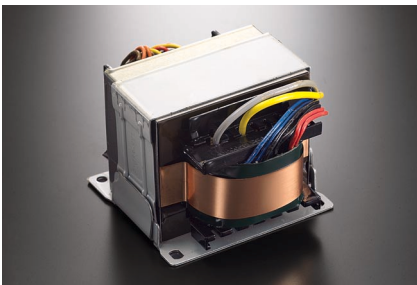
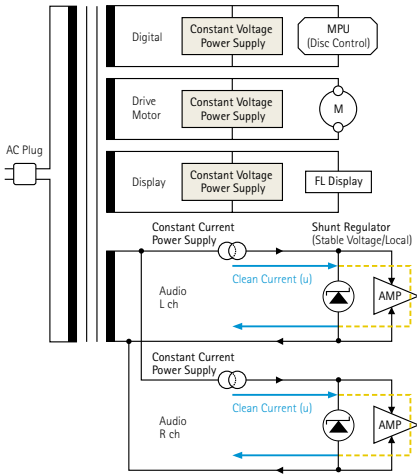

Pure Direct

The CD-S1000 provides the Pure Direct circuit that is a popular feature of Yamaha amplifiers and receivers. Since it has separate analogue and digital sections, the same as a

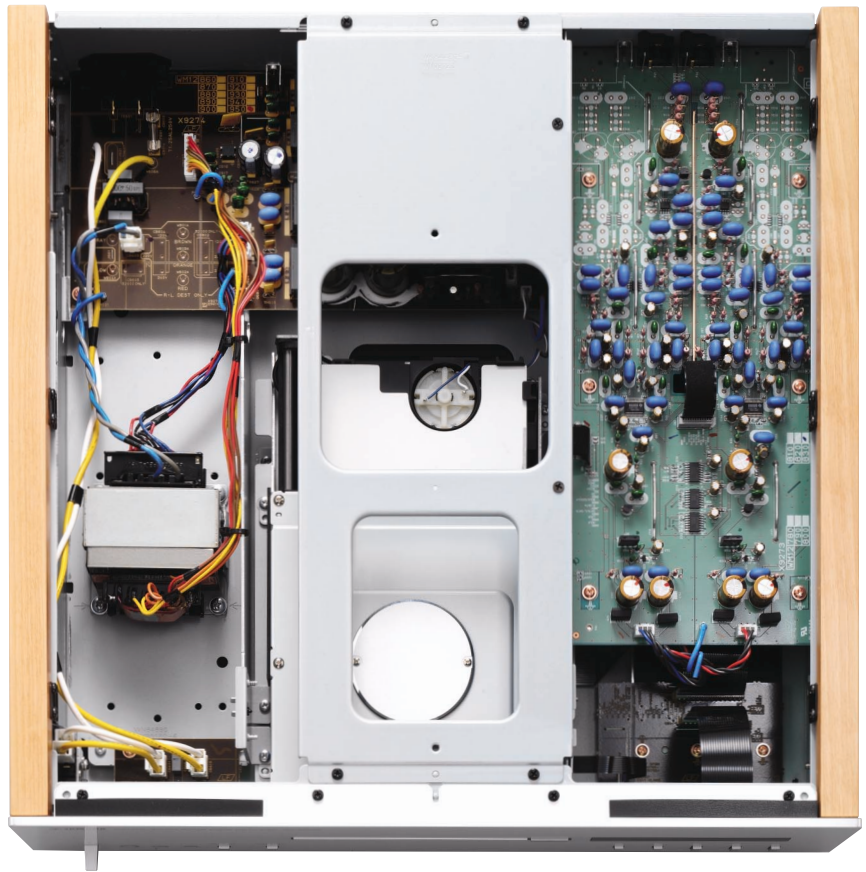

Left-right symmetrical design with rigid, stable construction

good amplifier, the designers decided to make use of Yamaha's amplifier technology to help achieve high sound quality. When Pure Direct is on, the display is turned off and digital output shuts down, providing the highest possible analogue sound quality.

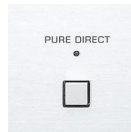

Construction

Like the A-S2000 and A-S1000 integrated amps, this player has a left-right symmetrical design with rigid construction, including a reinforcing bar

in the centre. Its specially designed feet stabilise the earth connection and provide superior protection from external vibration.

Specially Designed Feet

The base is equipped with height adjustable, solid steel feet that maximise stability and thoroughly dampen any external vibration.

Super Sound from Super Audio CDs

The CD-S1000 is capable of playing Super Audio CDs, for an even more dynamic listening experience.





Black finish available.

CD-S1000 Main Specifications

Frequency Response	CD Super Audio CD	2 Hz-20 kHz 2 Hz-50 kHz (-3dB)
Harmonic Distortion	CD/Super Audio CD (1 kHz)	0.002%
Signal-to-Noise Ratio	CD/Super Audio CD	113 dB
Dynamic Range	CD Super Audio CD	100 dB 105 dB
Output Level	CD/Super Audio CD (1 kHz, 0 dB)	2 ± 0.3 V
Dimensions	(W x H x D)	435 x 137 x 440 mm 17-1/8" x 5-3/8" x 17-5/16"
Weight		15 kg 33 lbs.



The perfect match:



A-S1000 Integrated Amplifier

For details please contact:

Visit us at our website:
<http://www.global.yamaha.com>

 **YAMAHA**
 CREATING 'KANDO' TOGETHER